

Angel

Designed by Mike Case

Difficulty: Intermediate
Folding time: 30 minutes

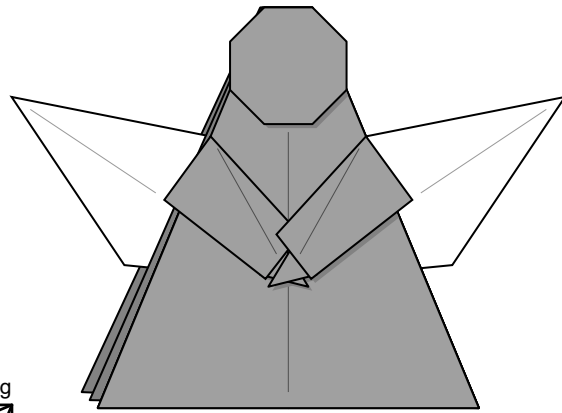

Ratio: 0.43

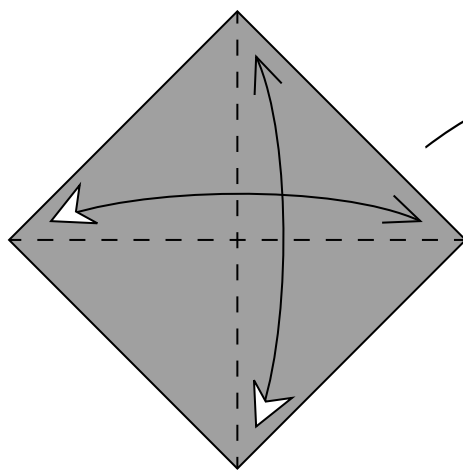
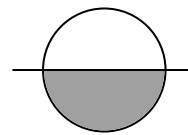
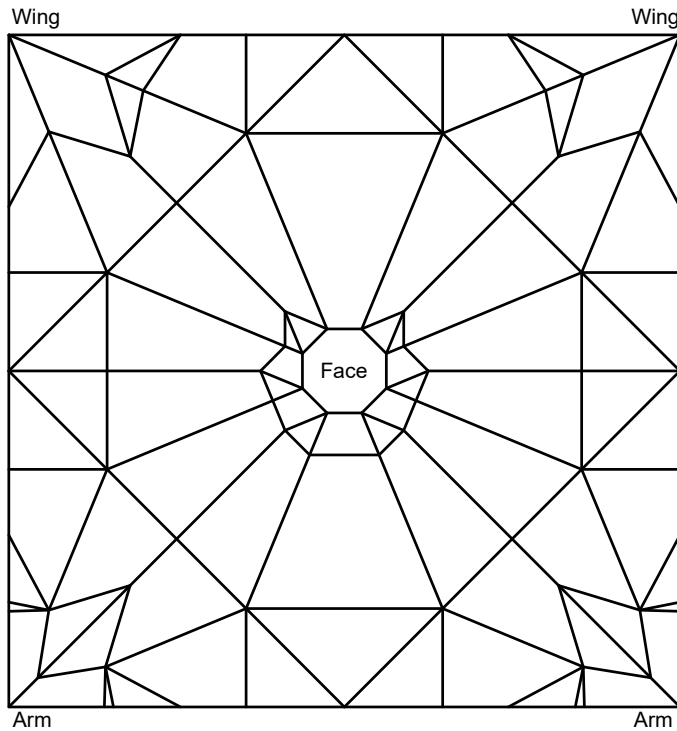
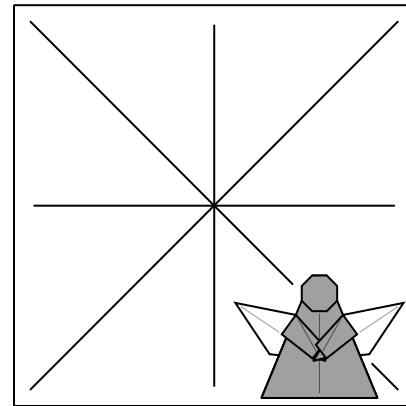

1. Fold along the diagonals and unfold.
Turn over.

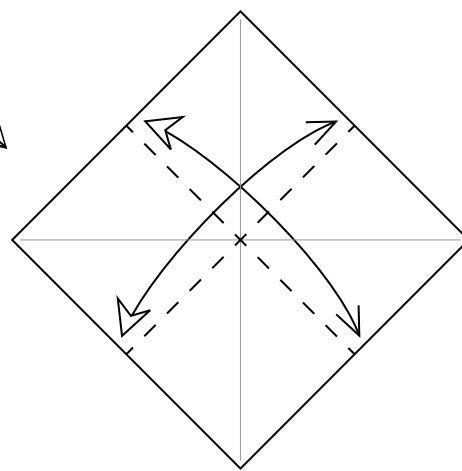
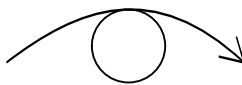

2. Valley lengthwise and
unfold.

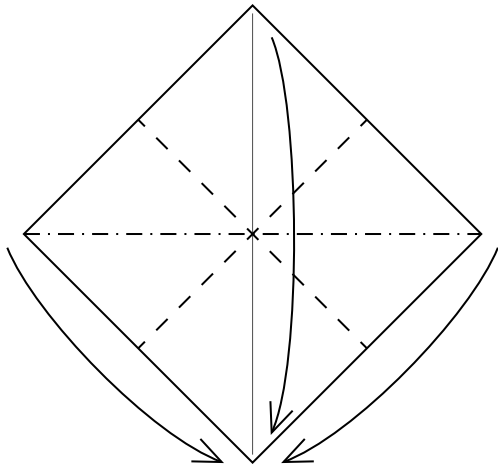

3. Collapse into a preliminary base.

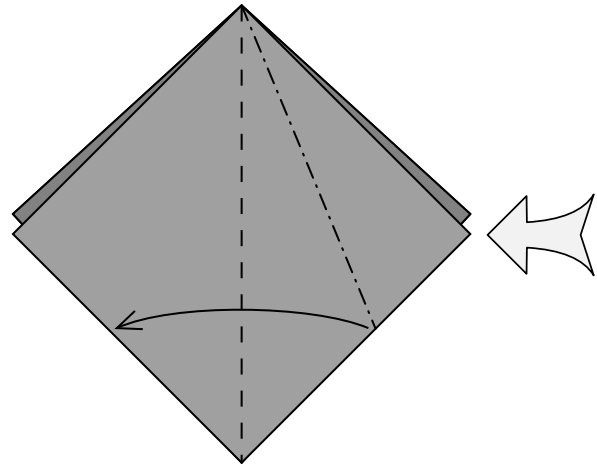

4. Squash fold the right flap to the left.

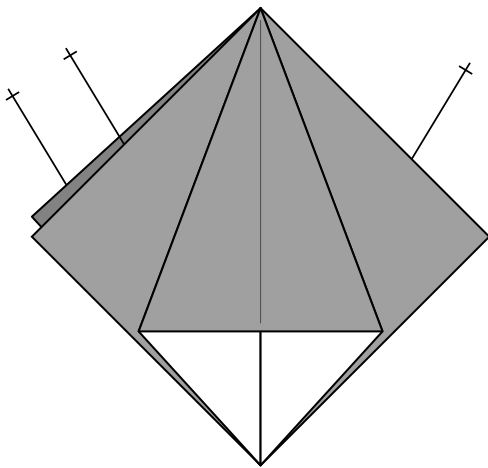

5. Repeat step 4 on the remaining 3 flaps.

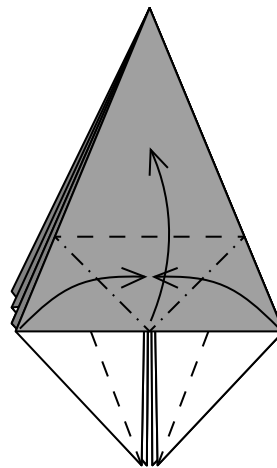

6. Petal fold.

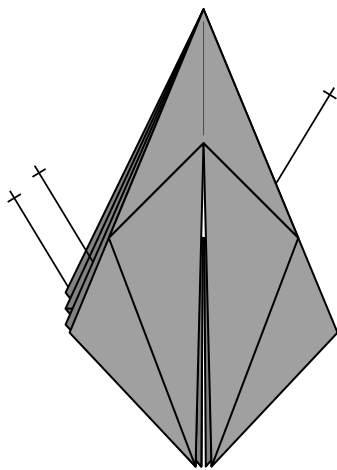

7. Repeat step 6 on the two sides and the rear.

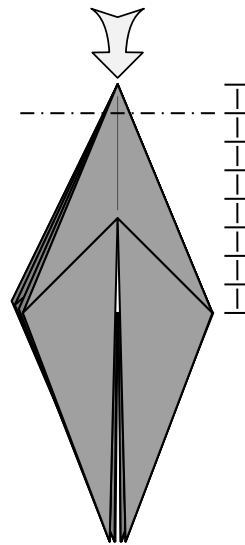

8. Sink the point about 1/8 between the point and the center of the model.

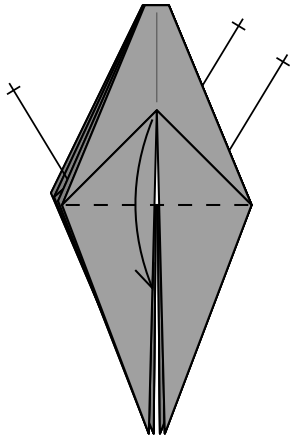

9. Valley fold the point down on each side.

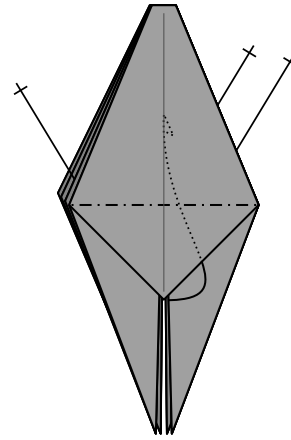

10. Mountain fold each point inside. Spreading the lower points will make this easier.

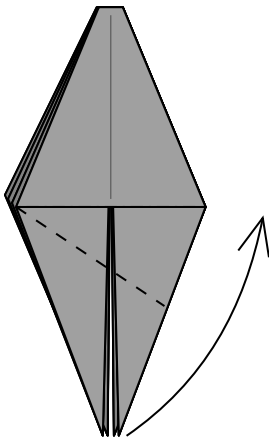

11. Valley fold both points up to the right so the edge of the left flap aligns with the horizontal fold.

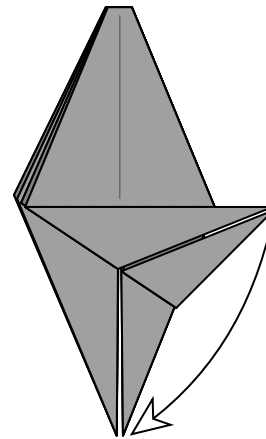

12. Unfold.

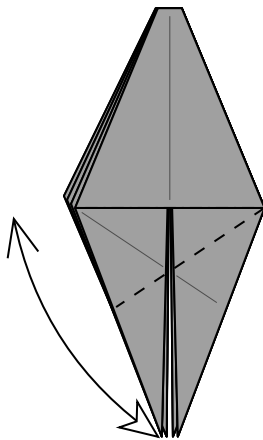

13. Valley fold both points up to the left, like in step 11. Unfold.

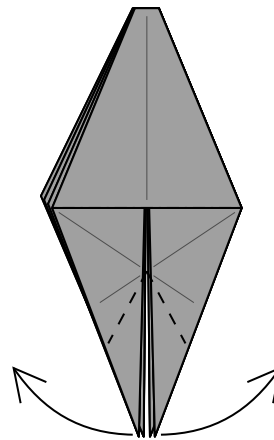

14. Valley fold the lower points outward to lie along the creases made in the previous step.

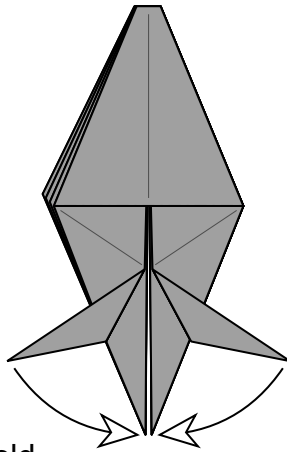

15. Unfold.

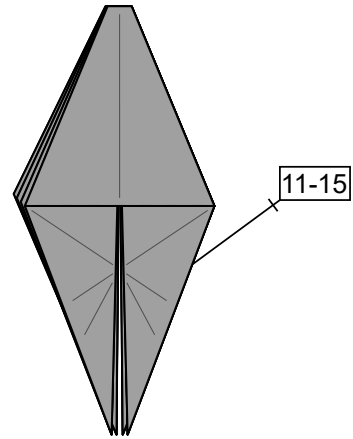

16. Repeat steps 11 to 15 on the back.

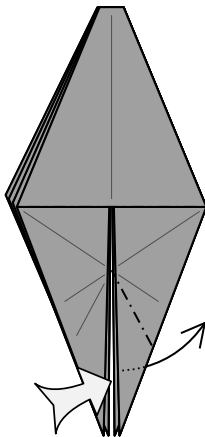

17. Inside reverse fold the point using the crease made in step 14.

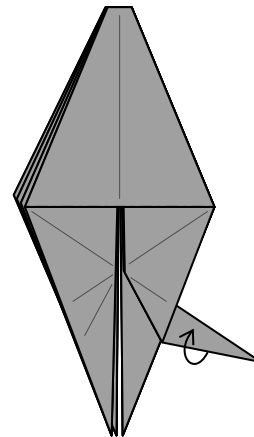

18. Pull one layer of paper out from the inside to change the colour. Repeat on the rear side of the flap.

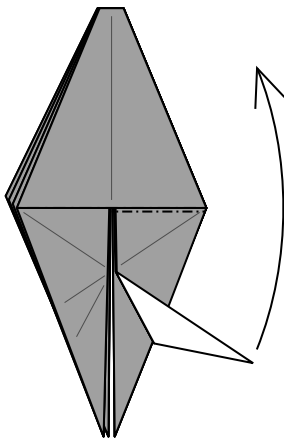

19. Mountain fold the point up between its flap and the flap behind it.

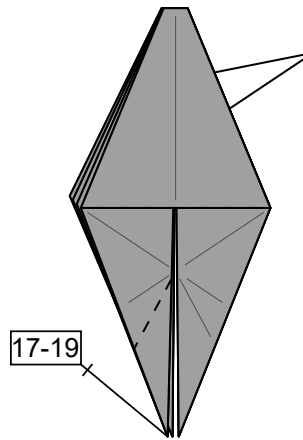

20. Repeat steps 17 to 19 on the left point.

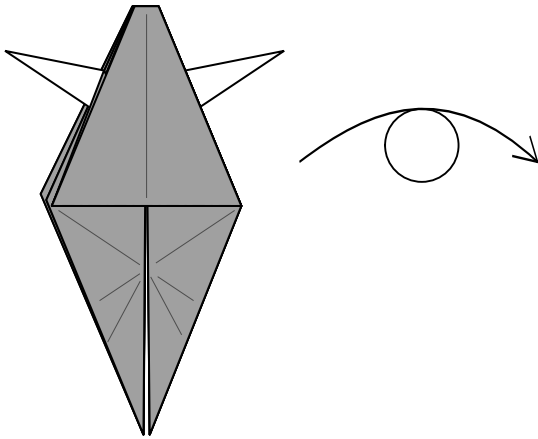

21. Turn over.

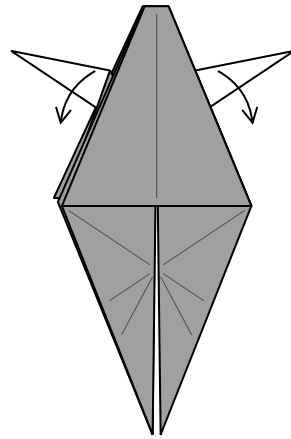

22. Mountain fold the front of each wing down.

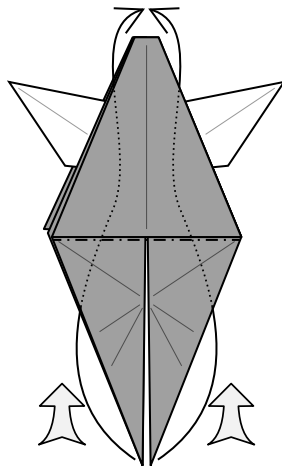

23. Inside reverse fold the lower two points straight up.

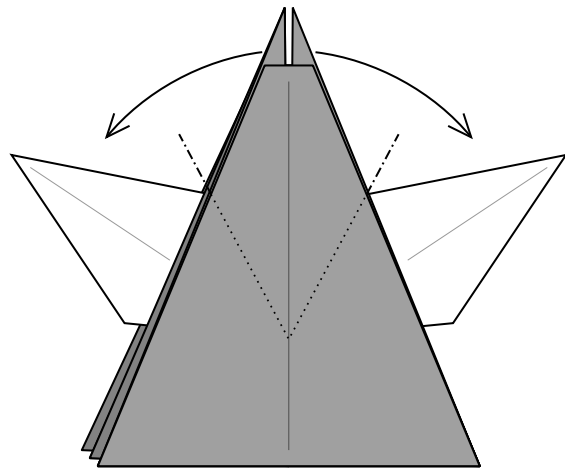

24. Inside reverse fold the top two points to the sides, using the creases made in step 14.

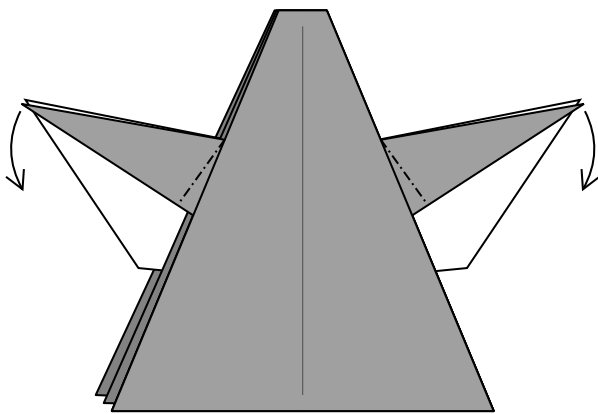

25. Crimp the outer layers of the arms downward while pushing some paper up from inside.

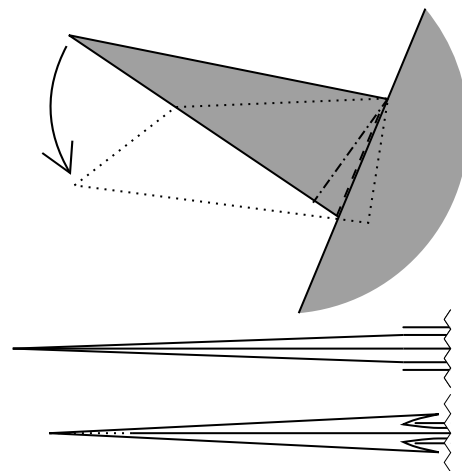

26. Details of the previous step. The center layer will not move down, but its tip will change from a mountain to a valley.

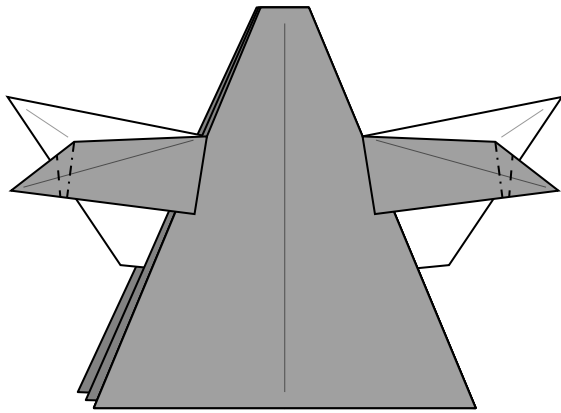

27. Crimp to form hands.

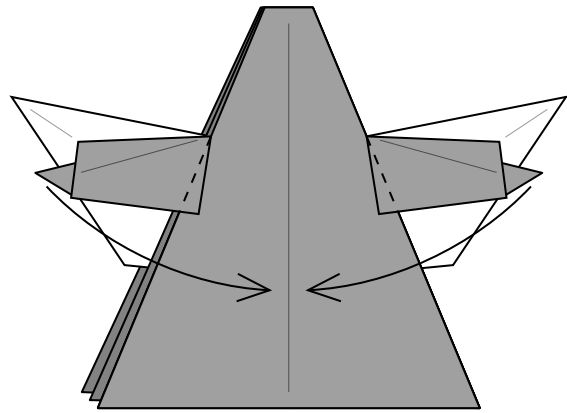

28. Valley fold the arms toward the center.

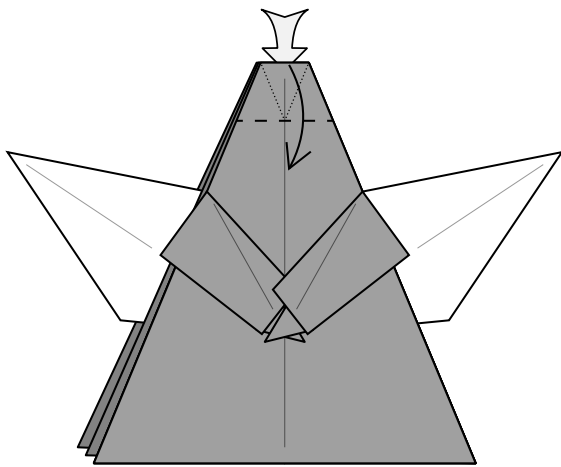

29. Valley fold the front part of the sink forward, spreading the sink to form the face.

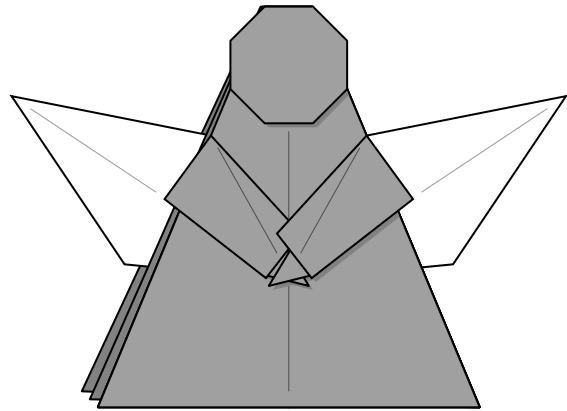

30. The finished angel.