

Banana Slug

Designed by Mike Case

Difficulty: Intermediate
Folding time: 30 minutes

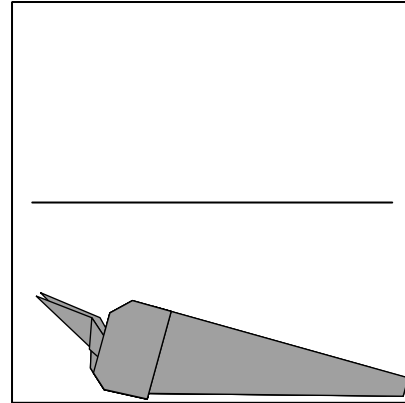
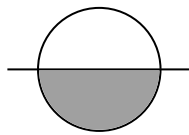
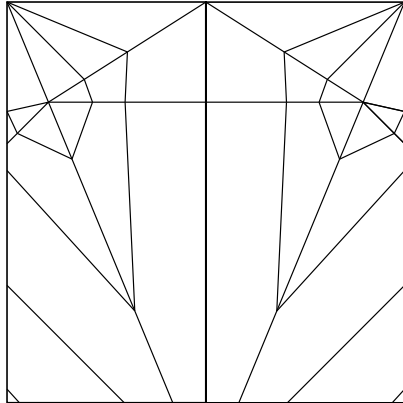
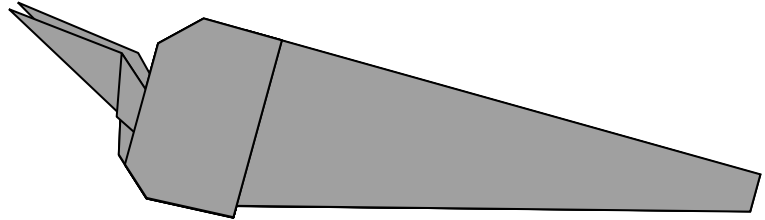

Ratio: 0.93

Notes:

- This model works quite well with a giraffe print paper.
- This model is very prone to paper creep. I recommend making the folds in steps 6, 10, and 15 fall a little short of the noted points

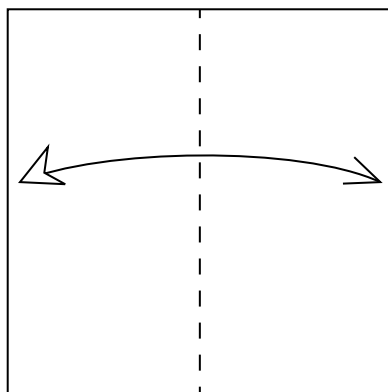

1. Fold in half and unfold.

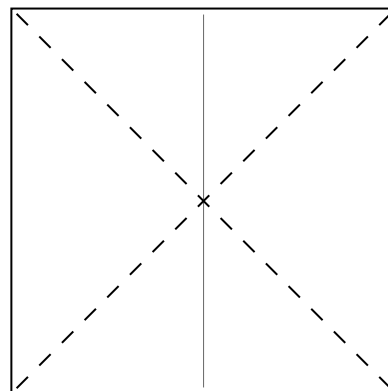

2. Valley fold along the diagonals and unfold.

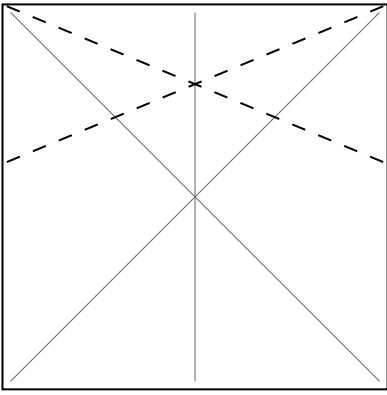

3. Valley fold the top edges down to the diagonals and unfold.

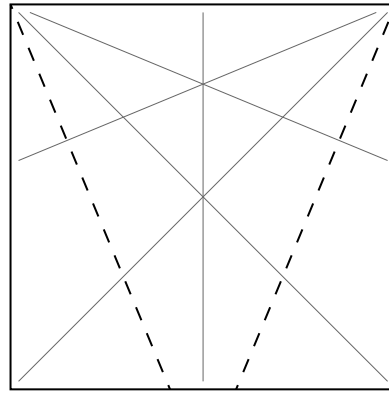

4. Valley fold the top edges down to the diagonals and unfold.

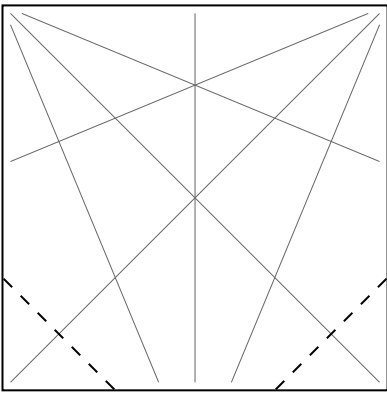

5. Valley fold the bottom corners up to meet the intersections of the creases from steps 2 and 4.

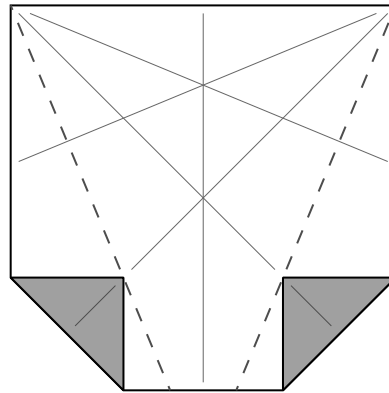

6. Valley fold the bottom corners up along the creases from step 4.

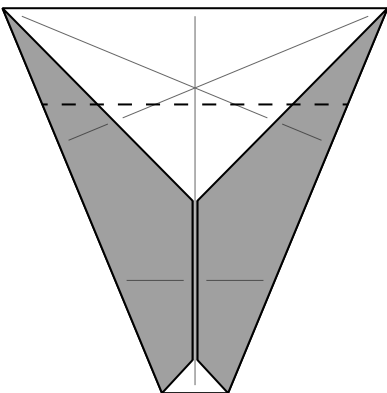

7. Valley fold the top edge to the center.

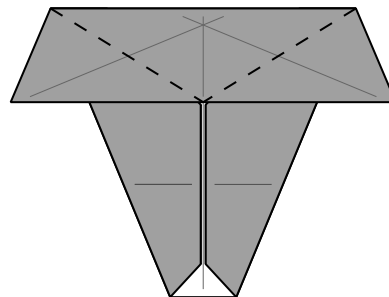

8. Valley fold the corners up.

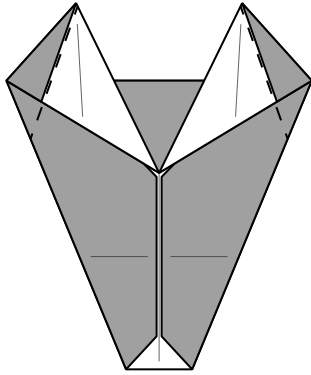

9. Valley fold edge to existing crease.

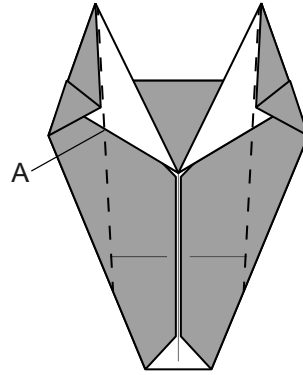

10. Valley fold the point in half. Note point A, where the creases cross the white section, as this will be used in step 12.

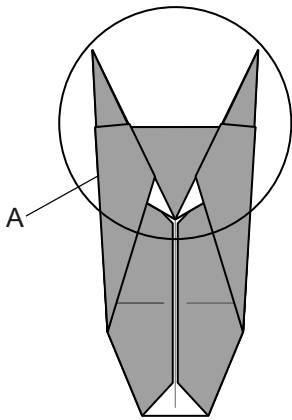

11. The model should look like this. The next steps will focus on the top of the model.

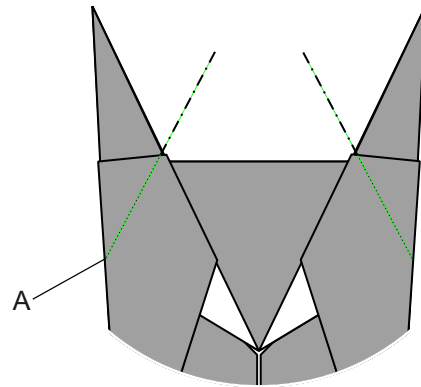

12. Mountain fold the points along a line connecting the top intersection to point A.

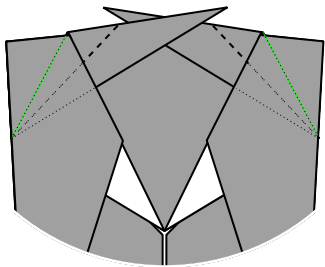

13. Valley fold the points in half along their length.

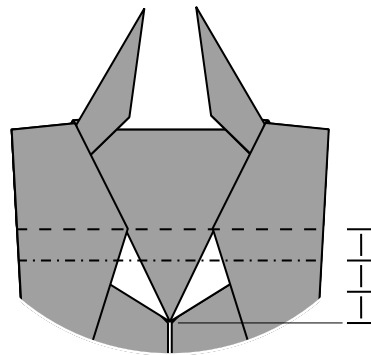

14. Crimp the top downward. The valley fold should pass through the top of the white triangles. The mountain fold should be about 1/3 of the way down to the lowest point of the white triangles.

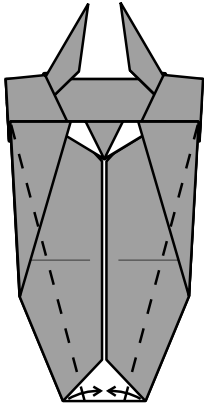

15. Valley fold the edges in so the top of the creases meet the top of the pleat, and the bottom corners lie on the center line.

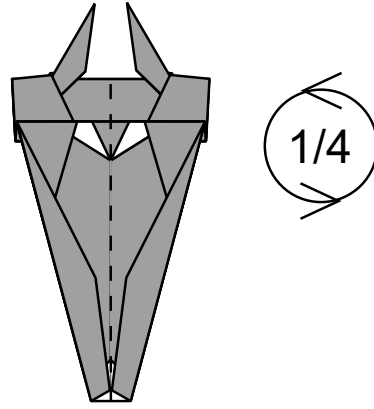

16. Valley fold the model in half and rotate 1/4 turn counter-clockwise.

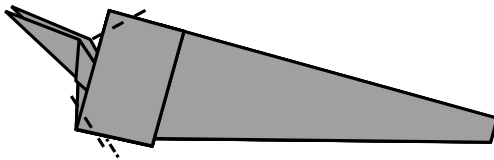

17. Shape the head by mountain folding the bottom corners and inside reverse folding the top corner.

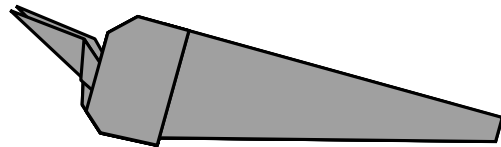

18. The finished slug.