

Puppy

Designed by Mike Case

Difficulty: Intermediate
Folding time: 30 minutes

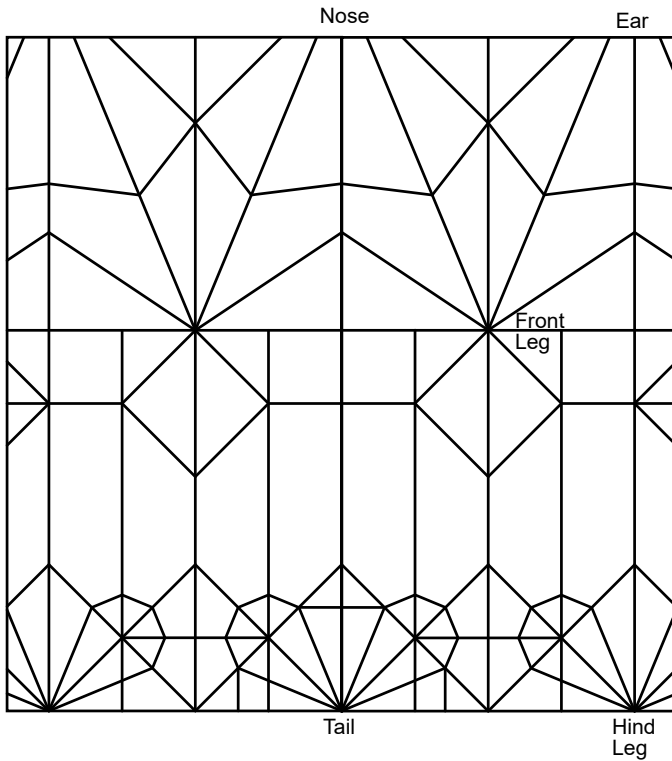
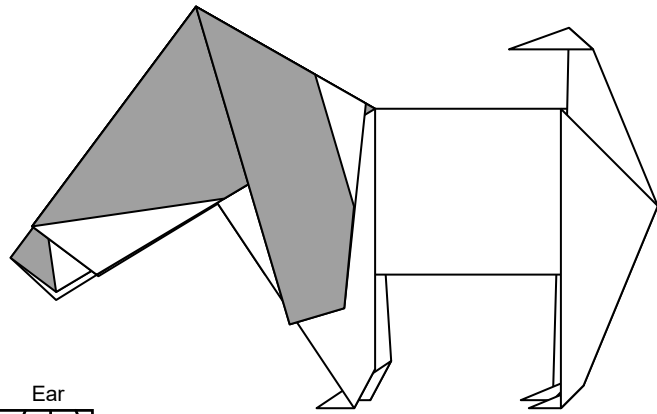

Ratio: 0.4

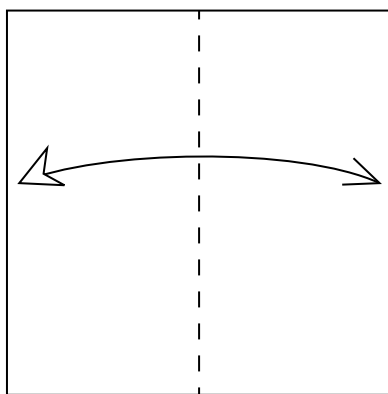
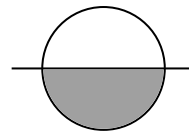
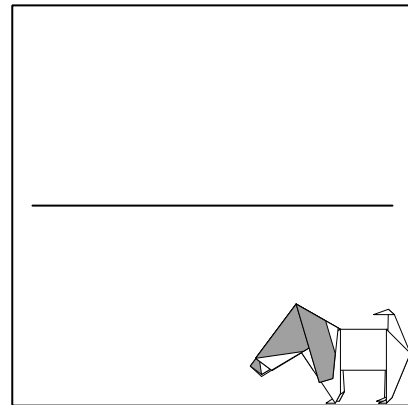

1. Fold in half and unfold.

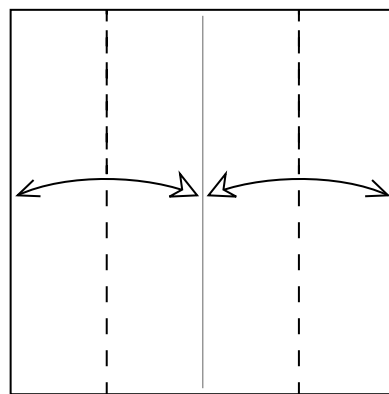

2. Valley fold the edges to the center and unfold.

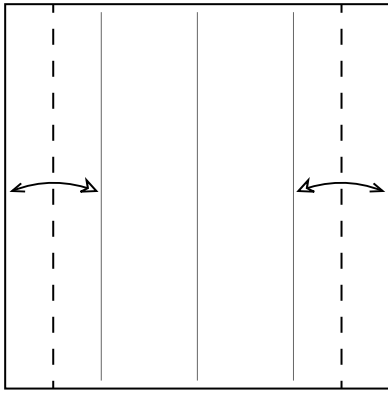

3. Valley fold the edges to the creases made in step 2 and unfold.

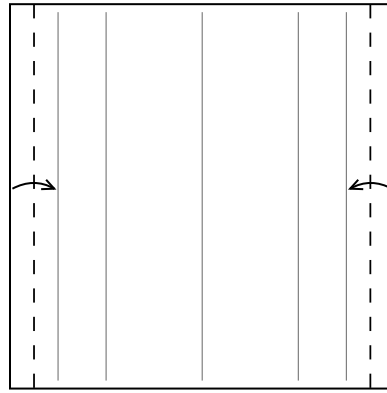

4. Valley fold the edges to the creases made in step 3.

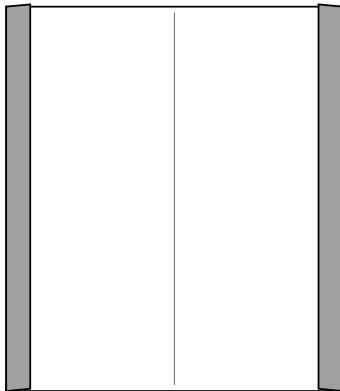

5. Flip over.

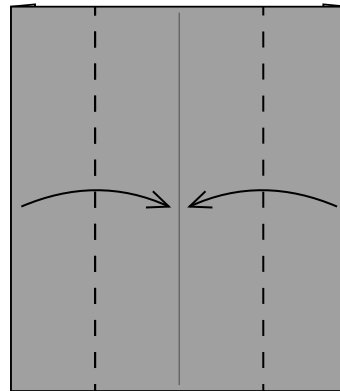
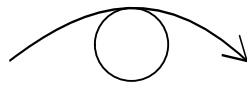

6. Valley fold edges to center. Rotate model 1/4 turn.

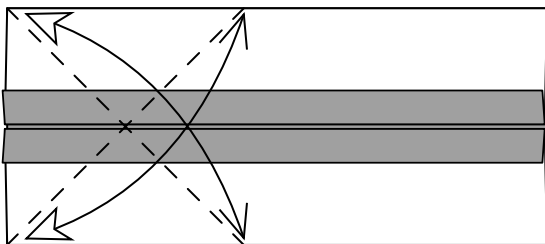

7. Valley fold and unfold diagonally where shown.

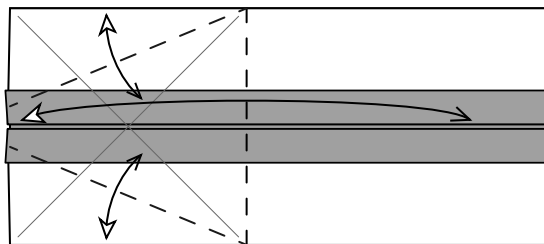

8. Valley fold the edges to the creases from step 7 and unfold. Valley fold where the creases from step 7 meet the sides and unfold.

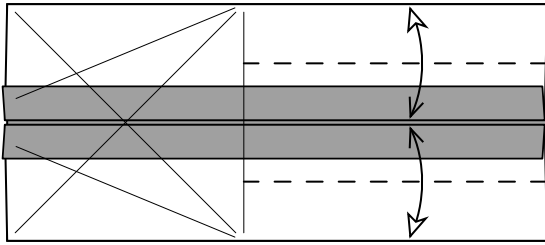

9. Valley fold edges to center only as far as the vertical crease from step 8 and unfold.

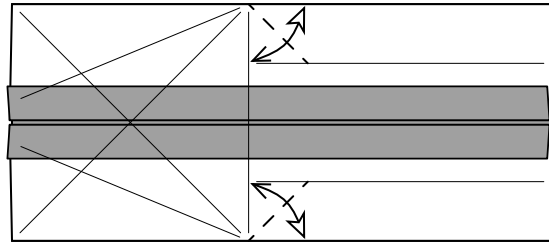

10. Crease diagonally where shown.

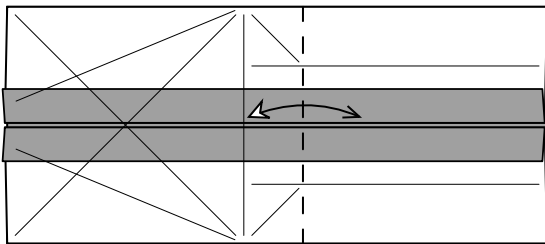

11. Crease vertically where the creases from step 10 meet those from step 9.

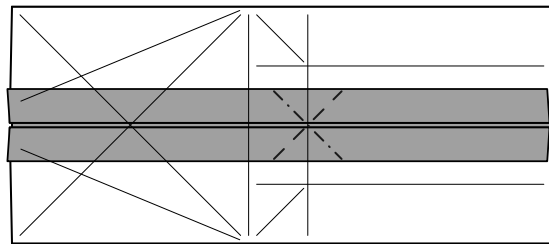

12. Mountain and valley crease only the top layer where shown.

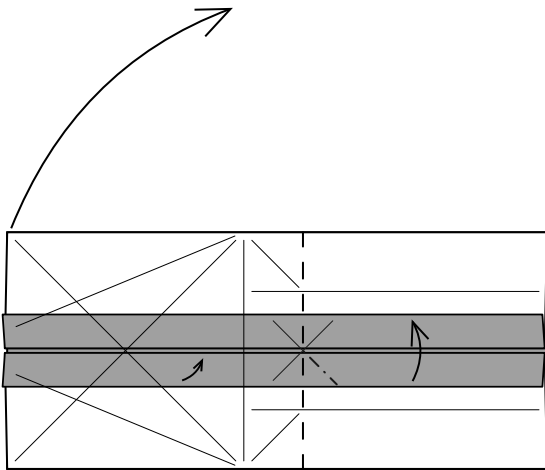

13. Fold the left half up so it makes a 90° angle with the right while folding the right hand part of the lower flap all the way over, and the left hand part of the lower flap so it is sticking out at 90°.

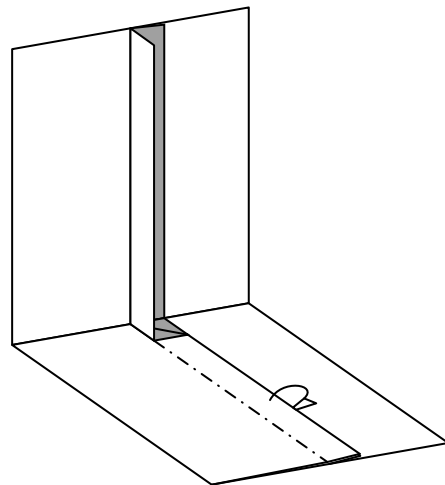

14. The model is now 3D. Mountain fold the flap underneath where shown.

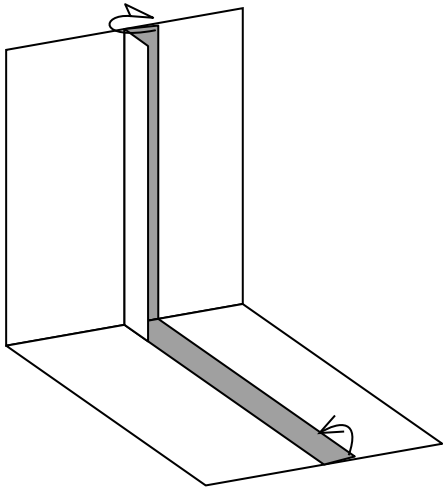

15. Repeat steps 13 and 14 on the other flap but inverted so the left part of the flap is tucked behind and the right part is up at 90°.

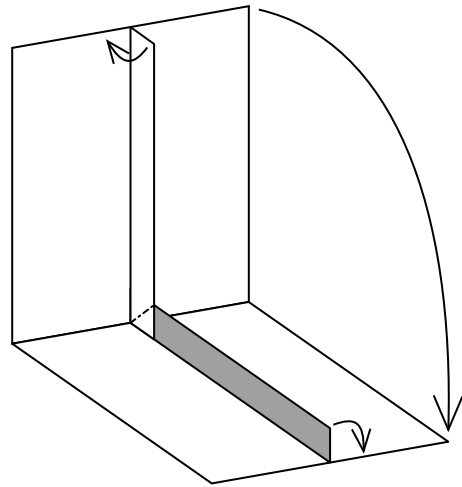

16. Close up the model while folding the flaps out using the creases from step 12.

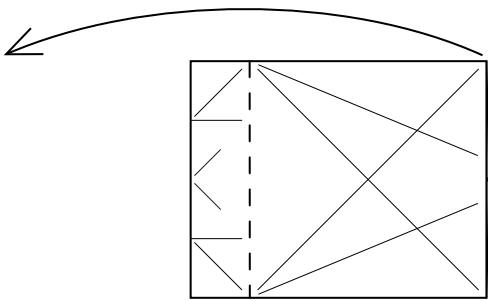

17. Valley fold the top layer to the left on the existing crease.

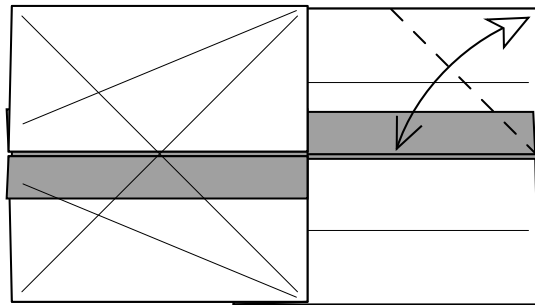

18. Valley fold the top right corner to the center and unfold.

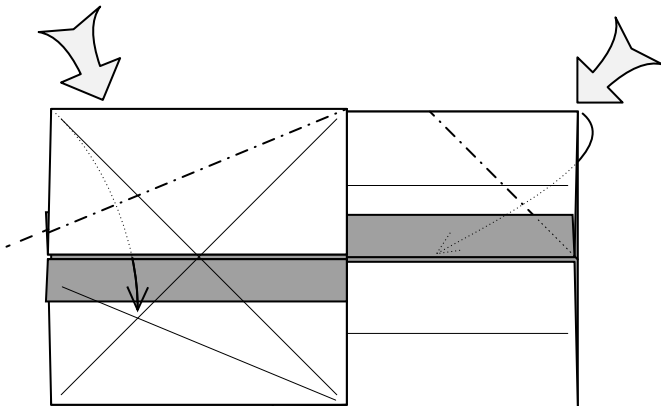

19. Inside reverse fold where shown along existing creases.

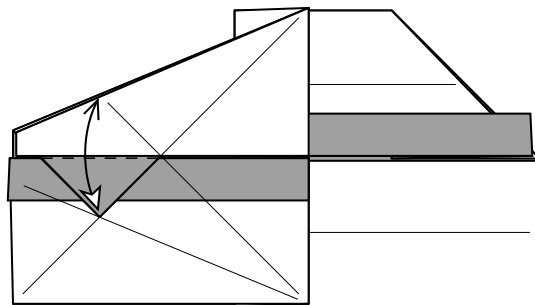

20. Valley fold the point up and unfold.

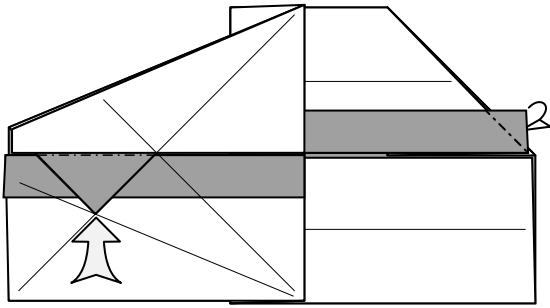

21. Inside reverse fold the point even with the center line. Tuck the little flap at the right under the top layer.

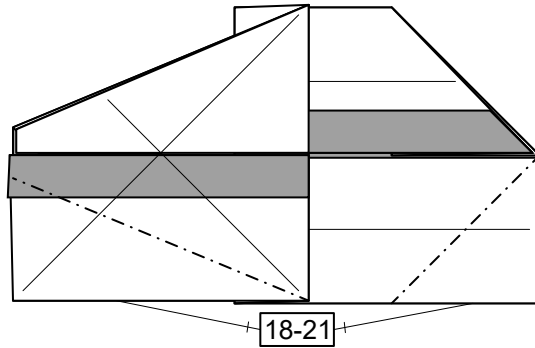

22. Repeat steps 18 to 21 on the bottom.

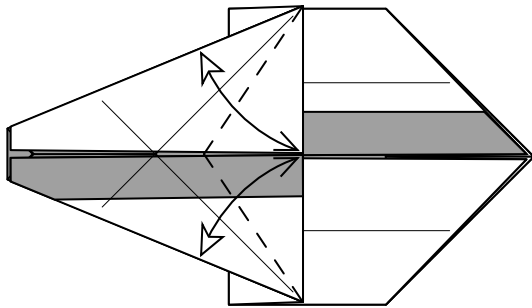

23. Valley fold the angle bisectors where shown and unfold. Crease only as far as the center line.

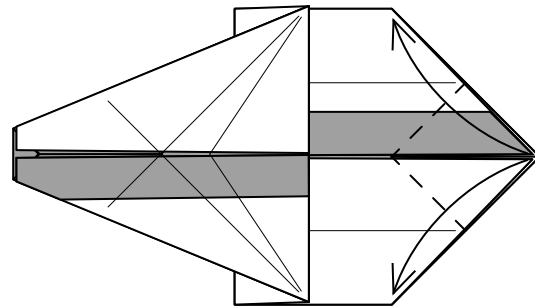

24. Valley fold the rear points to the sides.

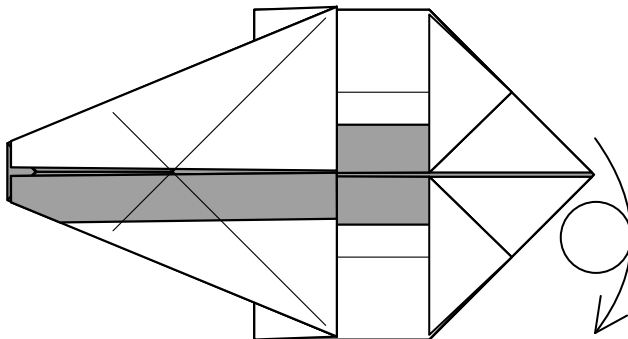

25. Flip model over.

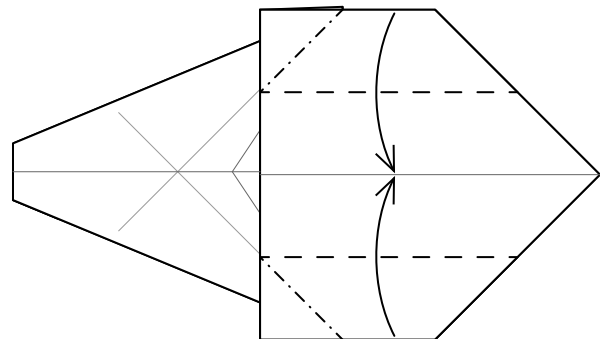

26. Valley fold the edges to the center along existing creases, squash-folding where shown.

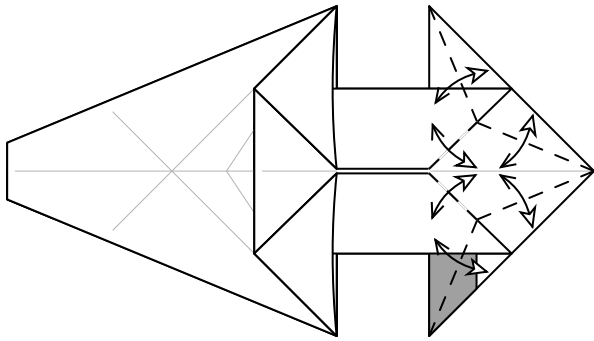

27. Valley fold along the angle bisectors shown, then unfold.

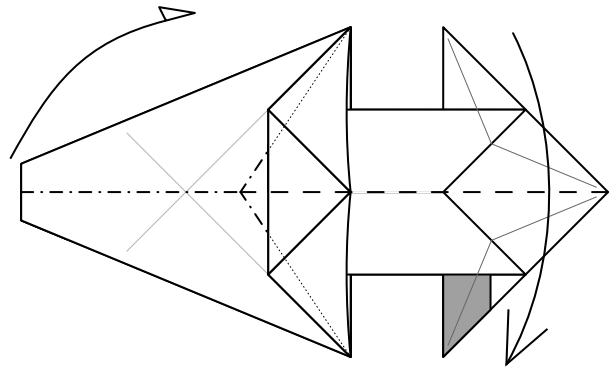

28. Rabbit ear the model in half along the creases and hidden creases shown.

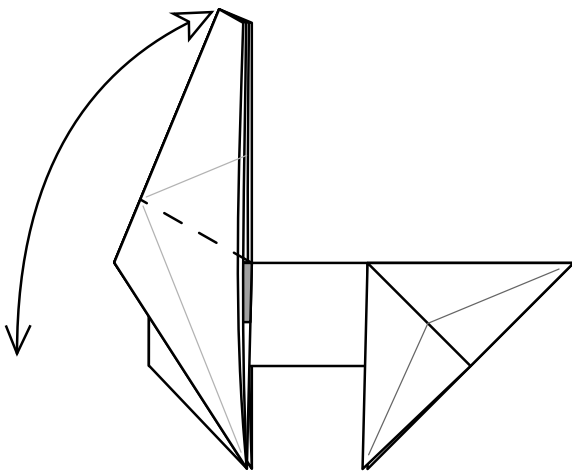

29. Valley fold on a line connecting the intersection of the two creases at the left and the point where the vertical edge meets the horizontal one, then unfold.

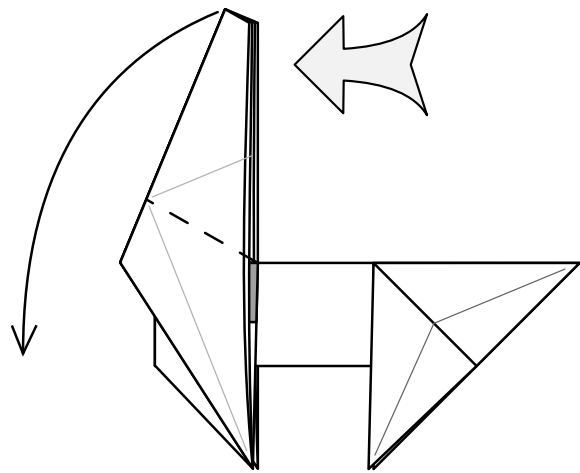

30. Outside reverse fold the head along the crease made in the previous step.

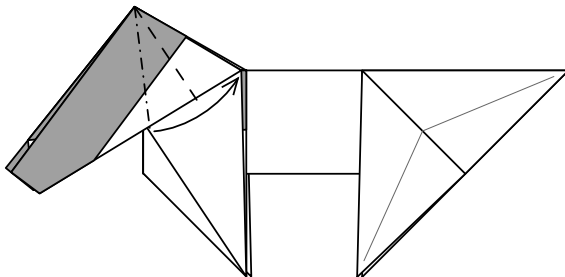

31. Crimp the ear to the right (the mountain part of the crimp is an existing crease); repeat behind.

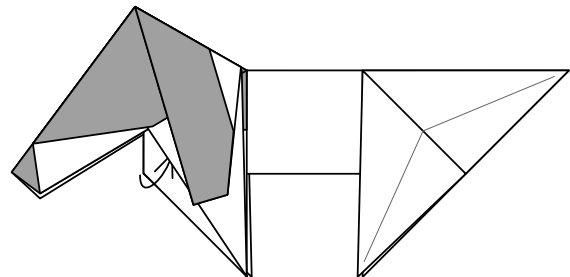

32. Valley fold the flap on the front leg into the pocket; repeat behind.

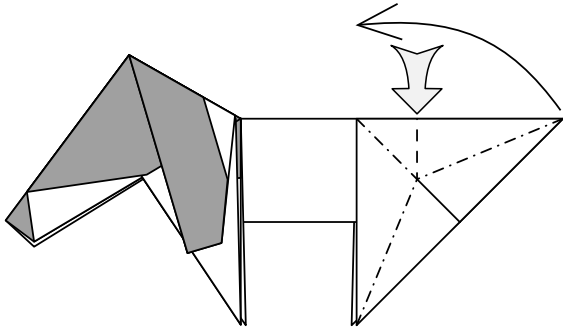

33. Double rabbit ear the tail.

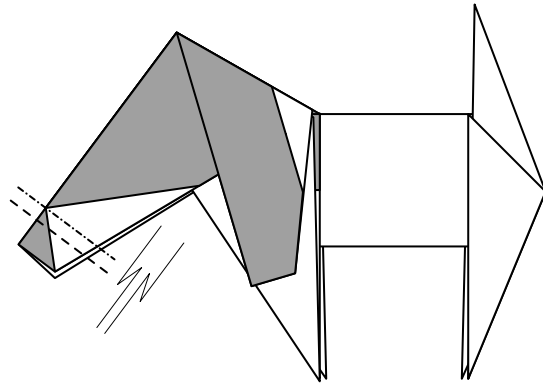

34. Crimp the tip of the snout inwards.

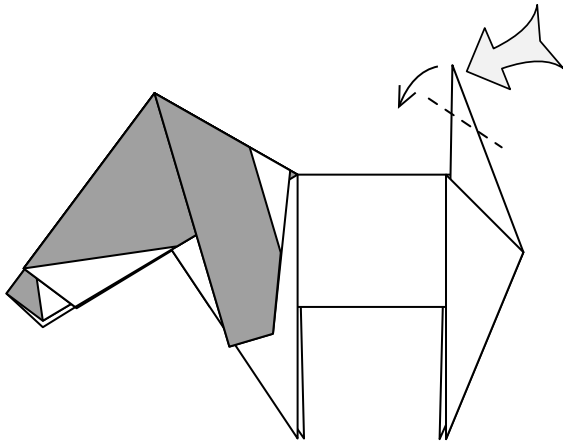

35. Outside reverse fold the tip of the tail.

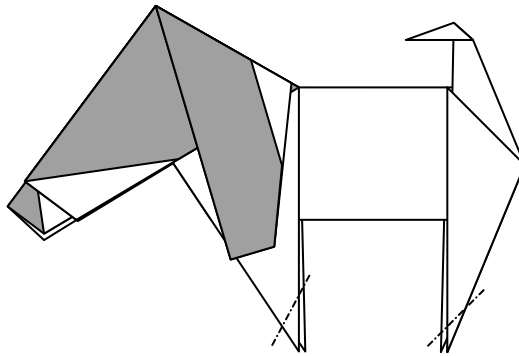

36. Reverse fold the bottom of the legs to form feet.

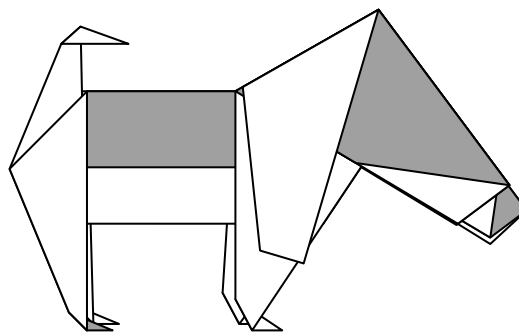
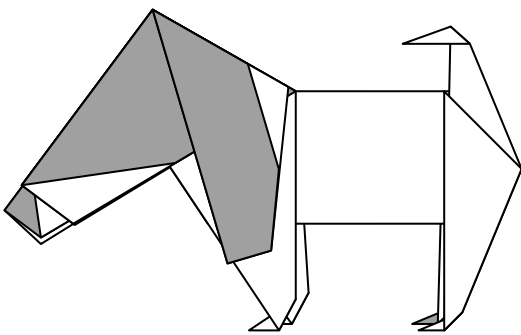

37. The finished puppy. Note: steps 13 to 16 create these specific markings. Switching up which flaps remain on top and which are tucked under will create a variety of markings.